



# **TIG 230**

## **AC/DC TROLLEY**

# Contents

<b>1. Safety</b> .....	<b>3</b>
<b>2. Package Contents</b> .....	<b>5</b>
2.1 Screws & Washers .....	5
2.2 Screw Assembly Groups .....	6
<b>3. Assembly</b> .....	<b>7</b>
<b>4. Installation</b> .....	<b>12</b>
4.1 Installing the Machine Only .....	12
4.2 Installing the Water Cooler & Machine .....	13
4.3 Installing the Gas Bottle on the Trolley .....	14

# 1. Safety

Welding equipment can be dangerous to both the operator and people in or near the surrounding working area if the equipment is not correctly operated. Equipment must only be used under the strict and comprehensive observance of all relevant safety regulations.

Read and understand this instruction manual carefully for all system components, especially the safety instructions and warning notices before the installation and operation of this equipment.

Product specifications and features are subject to change without notice. While every effort has been made to provide accurate and current information at the time of publication, this manual is intended as a general guide and is not exhaustive regarding safety, welding, or the operation and maintenance of this unit. Due to the many variables in the welding field and the evolving nature of both the field and the Xcel-Arc product line, Esseti NZ Ltd. does not guarantee the accuracy, completeness, authority, or authenticity of the information in this manual or provided by any Xcel-Arc employee during conversations or business dealings. The product owner assumes all liability for its use and maintenance. Esseti NZ Ltd. does not warrant this product or this document for fitness for any particular purpose, performance, accuracy, or suitability of application. Furthermore, Esseti NZ Ltd. accepts no liability for injury or damages, whether consequential or incidental, resulting from the use of this product or from the content of this document, nor does it accept third-party claims of such liability.

## Note:

- Observe the accident prevention regulations and any regional regulations.
- Safety and warning labels on the machine indicate any possible risks.
- Keep these labels clean and legible at all times.
- Technical changes due to further development in machine technology may lead to different welding behaviour.

**Items in the manual that require particular attention in order to minimise damage and harm are indicated with the below symbols. Read these sections carefully and follow their instructions.**

 **Note:** Gives the user a useful piece of information.

 **Caution:** Describes a situation that may result in damage to the equipment or system.

 **Warning:** Describes a potentially dangerous situation. If not avoided, it will result in personal damage or fatal injury.

## Operating Safety

- Only qualified persons should install, operate, maintain, and repair this equipment.
- During operation, keep everyone, especially children, away.



## Gas Cylinders

Shielding gas cylinders contain gas under high pressure. If damaged, a cylinder can explode. Because gas cylinders are usually part of the welding process, be sure to treat them carefully.

- Protect gas cylinders from excessive heat, mechanical shocks, physical damage, slag, open flames, sparks, and arcs.
- Ensure cylinders are secured upright to prevent tipping or falling over.
- Never allow the welding electrode, earth clamp, or electrical circuit to touch the gas cylinder, and don't drape welding cables over the cylinder.
- Never weld on a pressurised gas cylinder, it will explode and kill you.
- Open the cylinder valve slowly and turn your face away from the cylinder outlet valve and gas regulator. Stand to the side of the cylinder when opening the valve.
- Only use the correct gas, regulators, hoses, and fittings for your application and keep them in good condition.
- Keep full and empty cylinders separate.
- Keep ammonia-based leak detection solutions, oil and grease away from cylinders and valves.
- Never use force when opening or closing valves.
- Don't repaint or disguise markings and damage. If damaged, return cylinders immediately.
- When working with cylinders or operating cylinder valves, ensure that you wear appropriate protective clothing – gloves, boots and safety glasses.

## 2. Package Contents

### 2.1 Screws & Washers

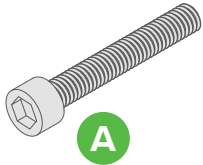

**M6x40 Screw**  
x8



**M6 Spring Washer**  
x20

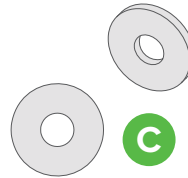

**M6 Large Flat Washer**  
x14



**M6 Nut**  
x8

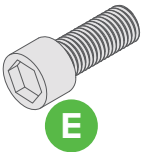

**M8x20 Screw**  
x8



**M8 Spring Washer**  
x8

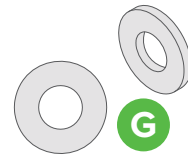

**M8 Flat Washer**  
x8



**M6x16 Screw**  
x12

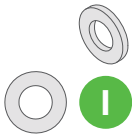

**M6 Flat Washer**  
x12

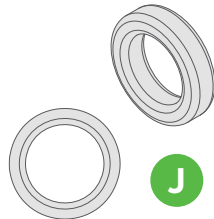

**Axle Sleeve**  
x2



**Cotter Pin**  
x2

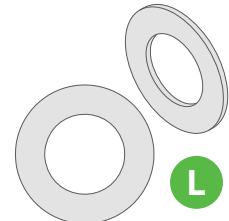

**M25 Flat Washer**  
x2



**M5x16 Screw**  
x8

## 2.2 Screw Assembly Groups

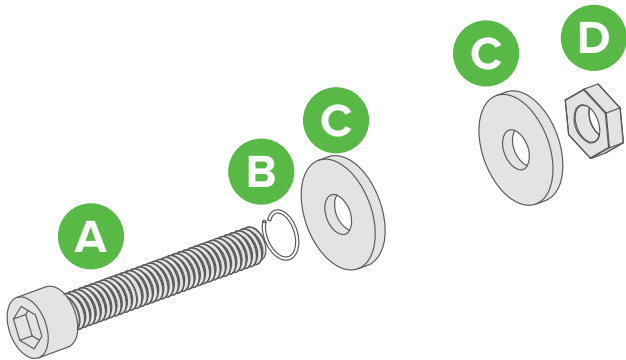

Group 1

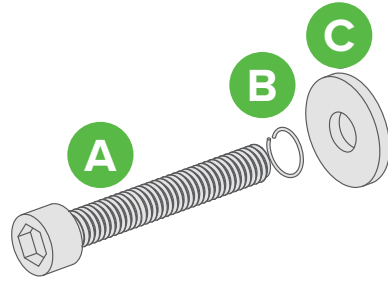

Group 2

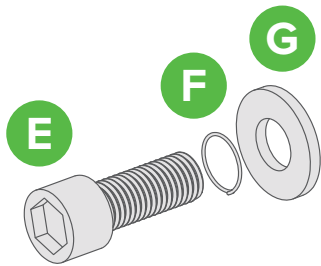

Group 3

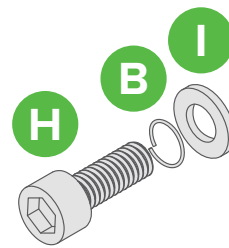

Group 4

## 3. Assembly

**Tools needed:**

- Phillips Head screwdriver
- Allen key set

### Step 1

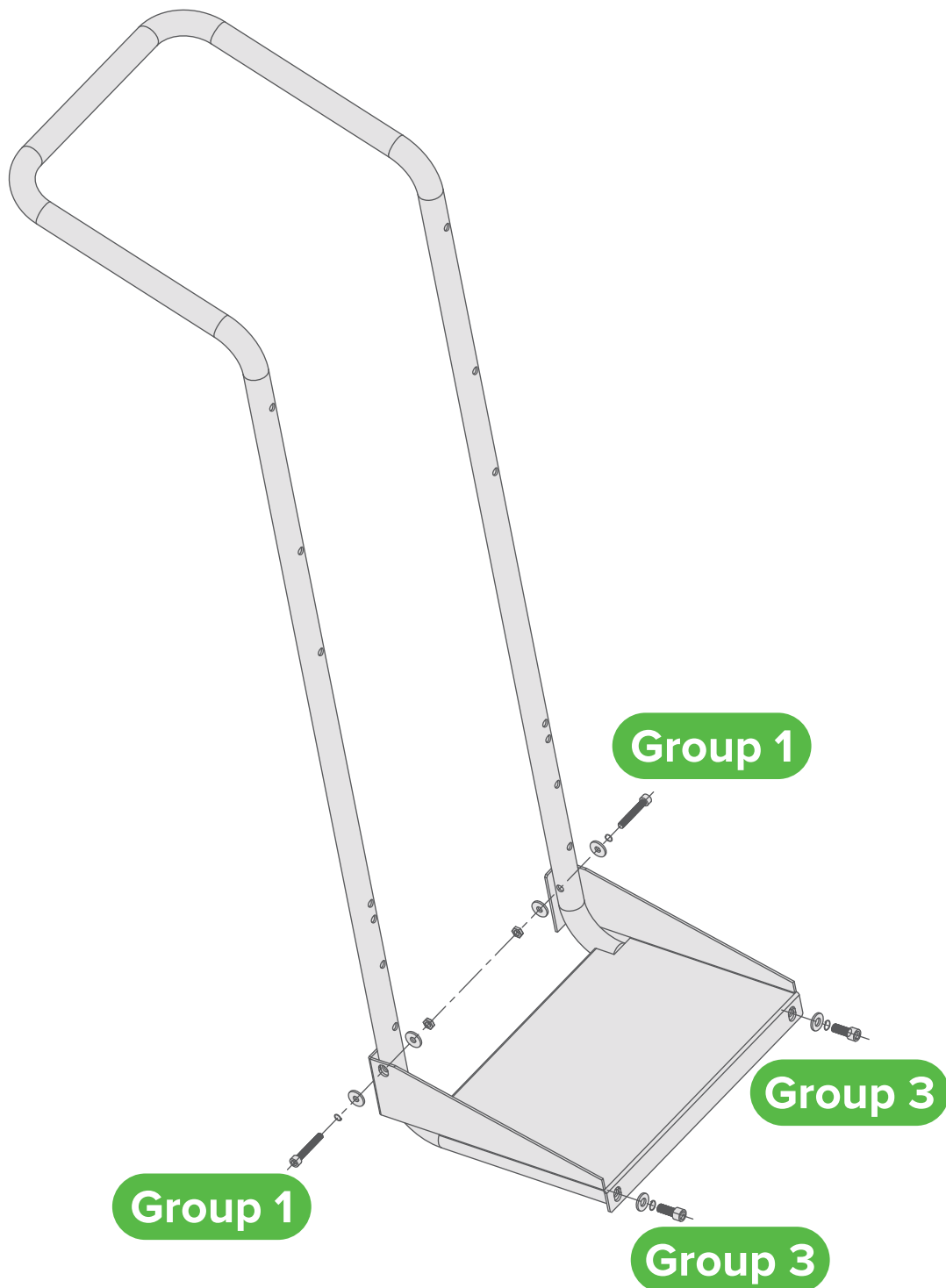

**Step 2**

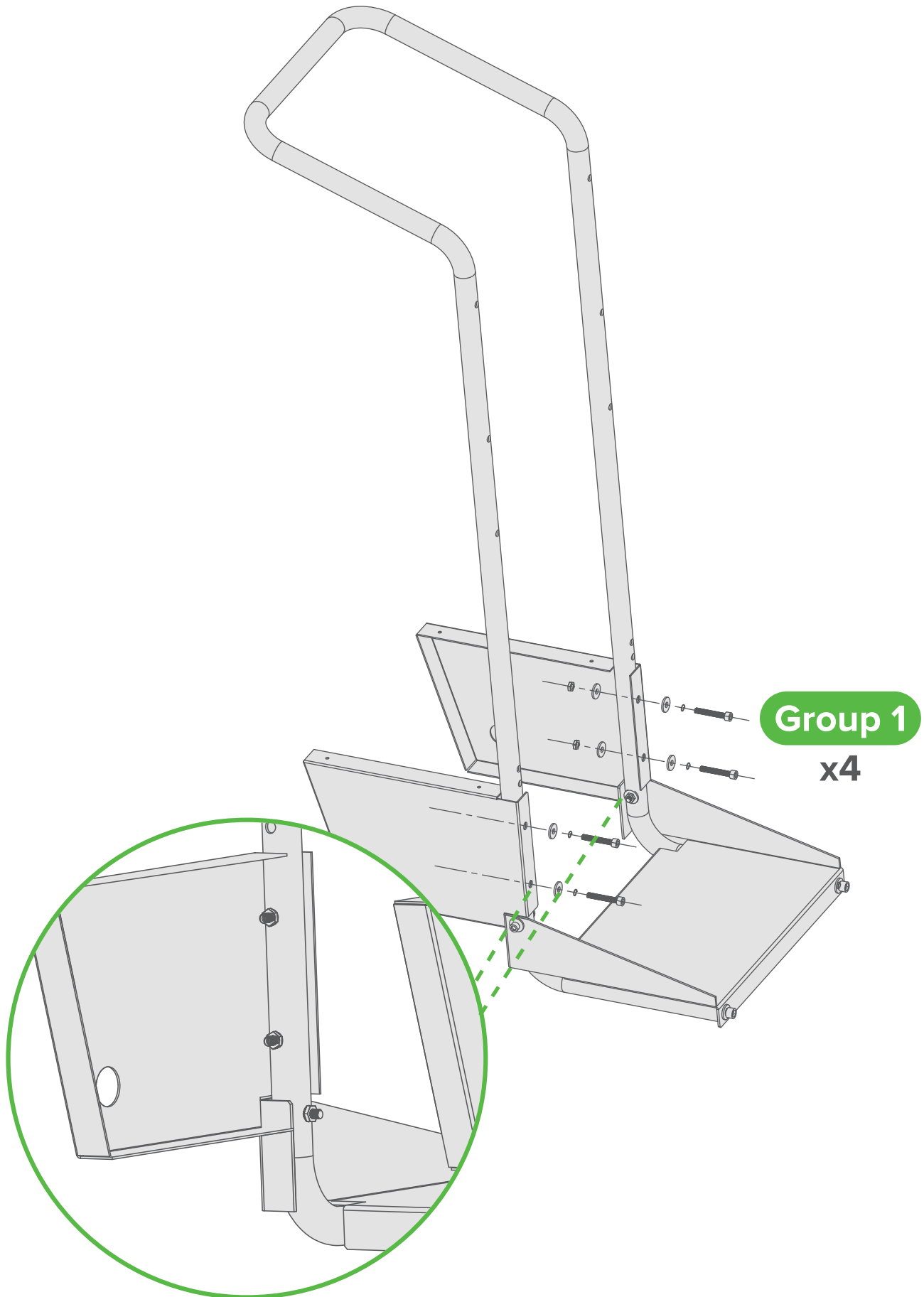

**Step 3**

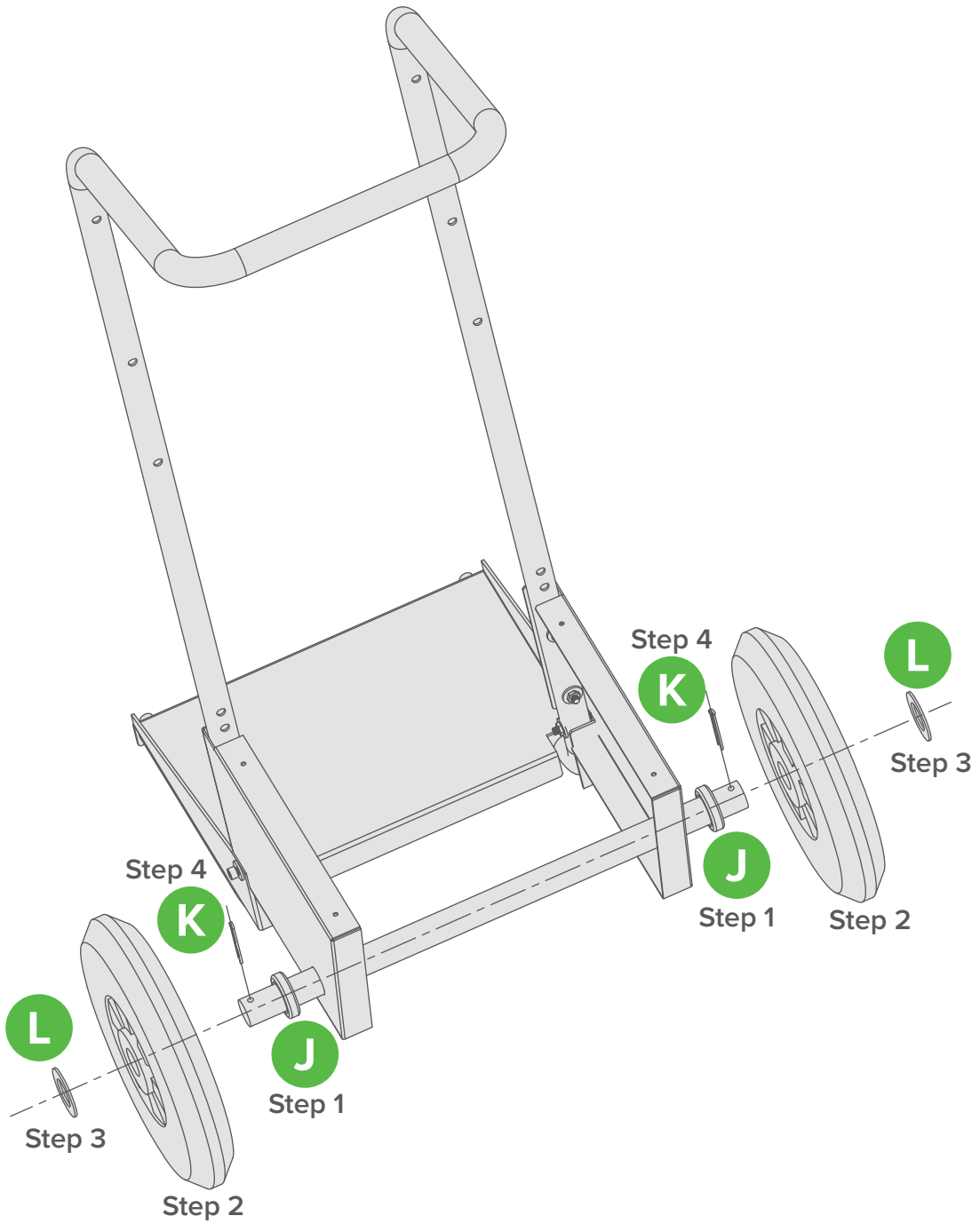

**Step 4**

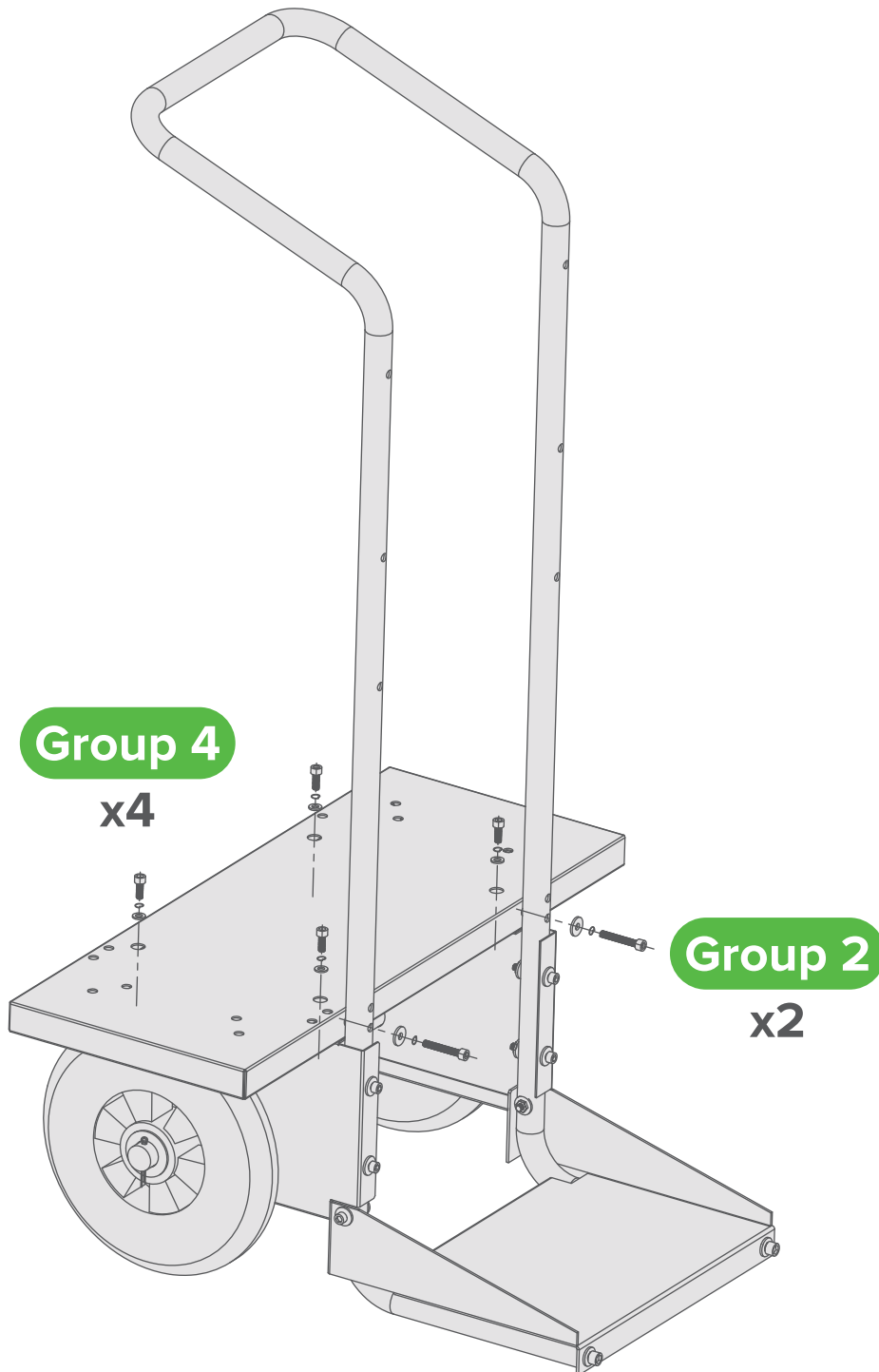

**Step 5**

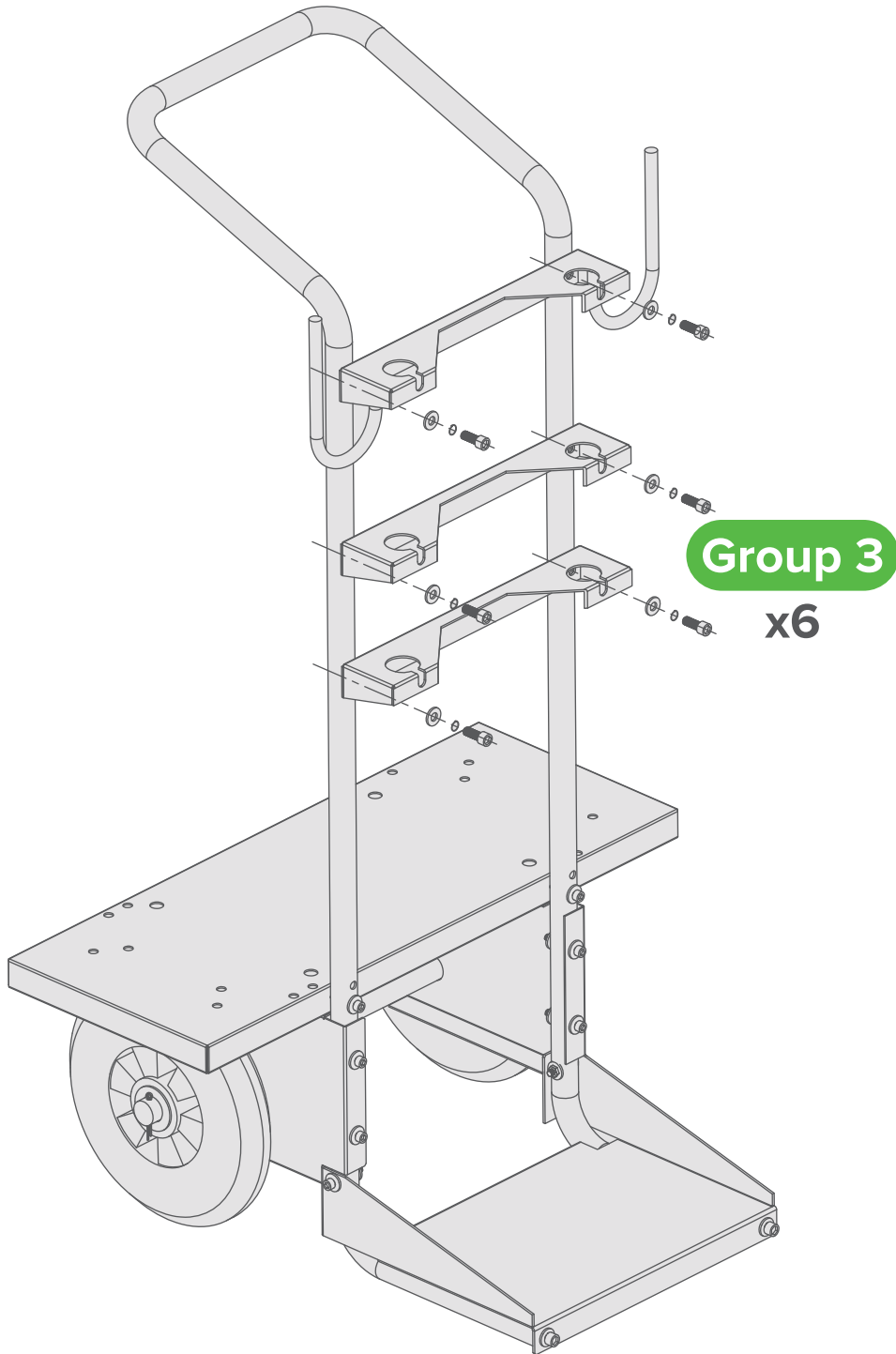

## 4. Installation

### 4.1 Installing the Machine Only

1. Attach the two L shaped mounting brackets onto the trolley.

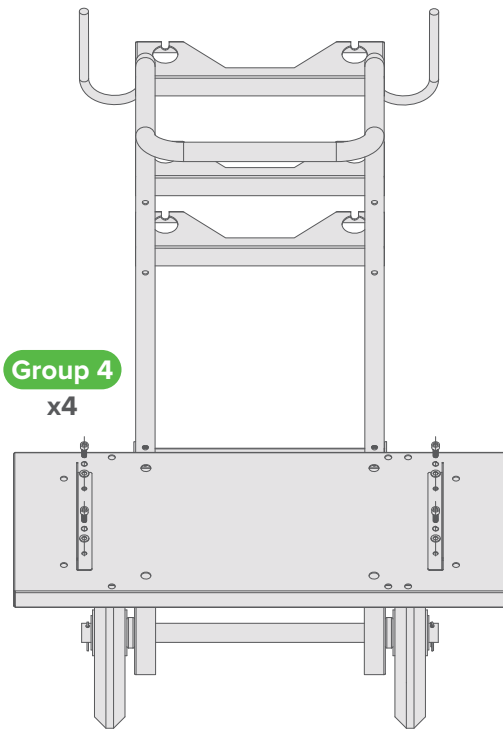

2. Place the machine on the trolley, so that the feet sit over the mounting brackets, and screw it in via the mounting points.

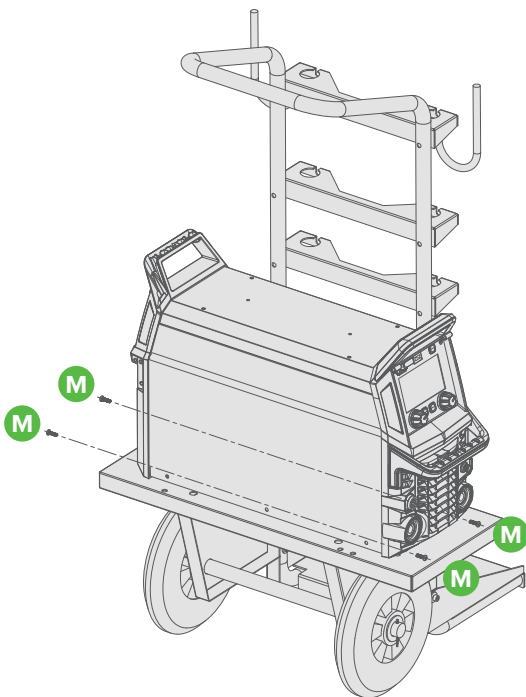

## 4.2 Installing the Water Cooler & Machine

1. Attach the two feet mounts to the bottom of the water cooler. It is recommended to do this before connecting the machine.

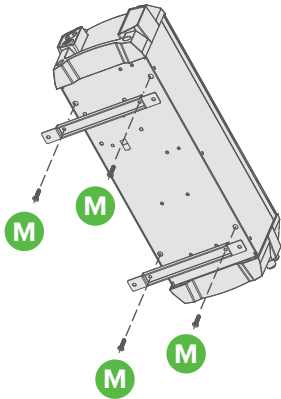

2. Place the water cooler on the trolley and screw it in via the mounting points.

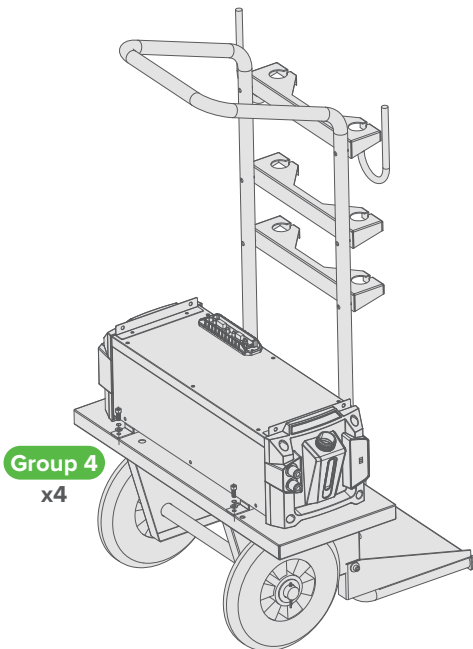

3. Place the machine on the water cooler and screw it in via the mounting points.

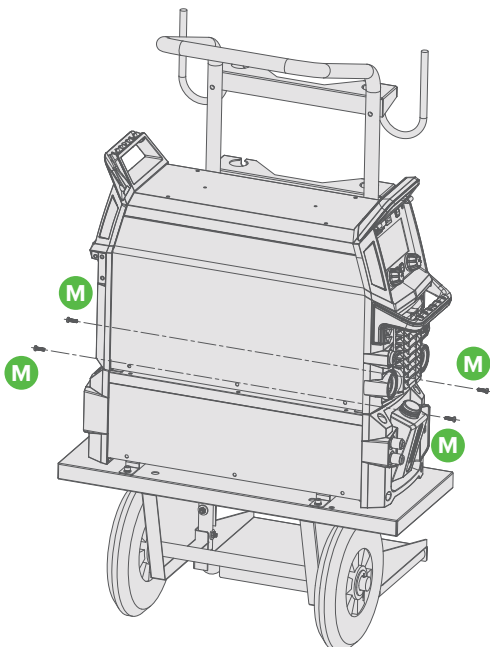

## 4.3 Installing the Gas Bottle on the Trolley

1. Move the gas bottle onto the trolley's gas bottle rack.

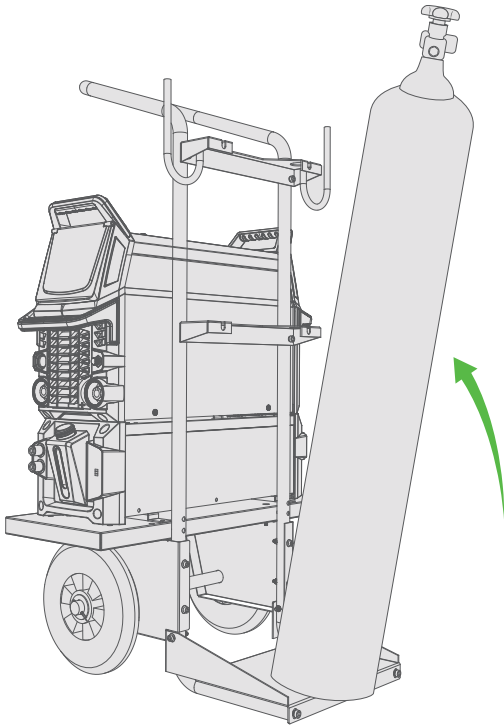

2. Secure the gas bottle in place with the chains. Use the dedicated fixing points on the trolley.

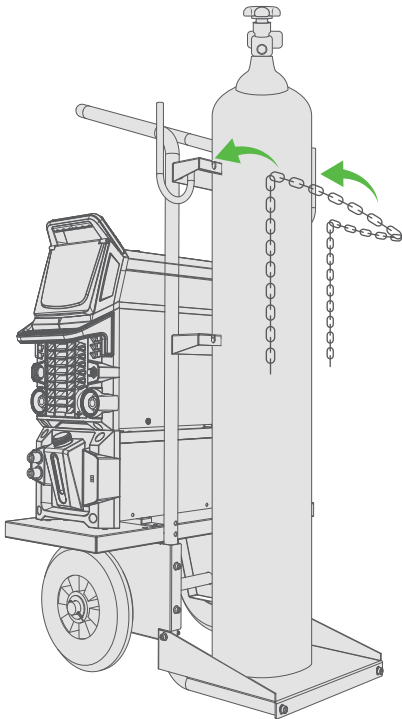

**⚠ There is a risk of accident if the gas cylinder is improperly or inadequately secured which could result in severe injury. The cylinder must be secured with at least two of the chains.**

# Notes

A series of horizontal dotted lines for taking notes, spanning the width of the page.



***Esseti New Zealand Limited***

PO Box 4189, Palmerston North - 4442

**Phone:** 06 355 1103

**Email:** [sales@esseti.co.nz](mailto:sales@esseti.co.nz)

**[www.esseti.co.nz](http://www.esseti.co.nz)**