

# OPERATION MANUAL



**For every person who will be engaged in operation and maintenance supervision, it is recommended to read through this manual before any operations, so as to permit optimum operation of this machine.**

## **INTRODUCTION**

**Thank you very much for purchasing this product. Read this instruction manual thoroughly to ensure correct, safe, and effective use of the machine. Read the manual first to understand how to operate and maintain the machine. Cooperation between colleagues in the workplace is essential for safe, smooth operation. Make sure you read, understand and take all necessary safety precautions.**

## **SAFETY PRECAUTIONS**









**This product is designed to be safe, but it can cause serious accidents if not operated correctly. Those who operate and repair this machine must read this manual thoroughly before operating, inspecting, and maintaining the machine. Keep the manual near the machine so that anyone operates the machine can refer to it as necessary.**

- **Do not use the machine carelessly without following the instructions in the manual.**
- **Use the machine only after you have completely understood the contents of the manual.**
- **If an explanation in the manual is difficult to understand, contact our company or sales service office.**
- **Keep the manual to hand at all times and read it as many times as is necessary for a complete understanding.**
- **If the manual becomes lost or damaged, place an order with our company or sales service office for a new one.**
- **When transferring the machine to a new owner, be sure to hand over this instruction manual as well.**

## **QUALIFICATIONS FOR MACHINE OPERATOR**

**Operators and repair staff of this machine must completely understand the contents of the instruction manual and have either of the following qualifications:**

1. **Gas welding foremen's license**
2. **Completion of gas welding training course**
3. **Approval by the Minister of Labor**

| Symbol  | Title                                      | Meaning   |
|---|--|---|
|    | General                                    | General caution, warning, and danger  |
|    | Be careful not to get your fingers caught. | Possible injury to fingers if caught in the insertion port  |
|    | Caution: Electric shock!                   | Possible electric shock under special conditions  |
|   | Ground this equipment.                     | Operators must ground the equipment using the safety grounding terminal.  |
|  | Pull out the power plug from the outlet.   | Operators must unplug the power plug from the outlet when a failure occurs or when there is a danger of lightning damage. |
|  | Caution against bursting                   | Possible bursting under certain conditions  |
|  | General                                    | General warning   |
|  | Caution: Hot!                              | Possible injury due to high temperature under certain conditions  |
|  | Caution: Ignition!                         | Possible ignition under certain conditions  |

# CONTENTS

|  |    |
|--|----|
| 1. Safety Information .....                                      | 2  |
| 1.1 General machine safety precautions .....                     | 2  |
| 1.2 Gas cutting safety precautions .....                         | 4  |
| 2. Location of safety labels.....                                | 6  |
| 3. Outline of machine .....                                      | 6  |
| 3.1 Features of machine.....                                     | 6  |
| 3.2 Name and function of each section.....                       | 6  |
| 3.3 Specifications .....   | 7  |
| 4. Preparation for operation .....                               | 8  |
| 4.1 Contents of package.....                                     | 8  |
| 4.2 Machine assembly .....                                       | 8  |
| 4.3 Preparation for operation.....                               | 9  |
| 5. Cutting operation .....                                       | 10 |
| 5.1 Safety measures prior to operation.....                      | 10 |
| 5.2 Ignition and flame adjustment.....                           | 10 |
| 5.3 Cutting and piercing method.....                             | 11 |
| 5.4 Procedures for starting cutting and extinguishing flame..... | 11 |
| 5.5 Safety measures against backfire and flashback.....          | 11 |
| 5.6 Cutting operation.....                                       | 12 |
| 5.7 Set up circle cutting attachment .....                       | 12 |
| 5.8 Circle rail .....  | 12 |
| 6. Maintenance and inspection.....                               | 12 |
| 6.1 Daily inspection.....  | 12 |
| 6.2 Monthly inspection.....                                      | 12 |
| 6.3 3-month(2000-hour) inspection.....                           | 13 |
| 7. Troubleshooting.....  | 13 |
| 8. Wiring diagram .....  | 15 |
| 9. Sketch drawing .....  | 15 |
| 10. Parts list .....   | 16 |
| 10.1 Main units.....   | 16 |
| 10.2 Electrical, gas and torch slide holder units.....           | 18 |
| 10.3 Two torch unit.....   | 20 |
| 11. Cutting Data .....   | 22 |

## **Safety information**

Many accidents are caused by operation, inspection, and maintenance which disregard the basic safety rules. Carefully read, understand, and master the safety measures and precautions described in this instruction manual and on the machine before operating, inspecting, and maintaining the machine.

The safety messages are classified as follows for machine safety labels:

### **WARNING**



This word is used in a warning message and a warning label at places that could cause injury or serious accident.

### **CAUTION**



This word is used in a caution message and a caution label at places that could cause slight injury or machine damage. This is also used as a caution for frequent dangerous actions.

### **NOTICE SIGNS**



This is a sign to show machine operators and maintenance engineers items that relate directly to damage of machines and surrounding facilities and equipment.

## **1.1 General machine safety precautions**

Read and fully understand the following important safety information:

### **1.1.1 Machine safety**

1. The machine casing is mainly made of aluminum alloy to reduce weight. For this reason, be careful not to drop a heavy item on the machine, or not drop the machine when carrying it since the alloy is not designed to withstand such impact.
2. When mounting hoses to the torch and distributor, tighten the nut with the attached wrench. After mounting, be sure to check there is no gas leak with a detection liquid. If a gas leak is found, retighten the nut firmly.
3. When fixing a tip to the torch, tighten the nut with the two wrenches attached. In addition, avoid damaging the taper of the tip since this may cause backfire.
4. Never disassemble the machine other than during maintenance and inspection. Otherwise, malfunction will result.
5. Never remodel the machine. Remodeling is very dangerous.
6. When changing the direction, make sure that the direction switch is in the neutral (stop) position, and operate the direction switch after the machine has stopped.
7. Always turn the power off when not in use.
8. Never use the machine outdoors when the weather is wet. This will cause failure of the machine and could cause a fatal accident by electric shock.

### **1.1.2 Safety clothing**

1. Be sure to wear protectors (gauntlets, goggles, helmet, and safety shoes) during operation.
2. Avoid operating the machine with wet clothes or hands in order to prevent electric shock.

### 1.1.3 Operation and handling safety precautions

1. Read this instruction manual before operating the machine.
2. Mount and center the machine correctly and confirm correct motion before operation.
3. Before connecting the power plug to the outlet, make sure that the power switch is in the OFF position (or the normal/reverse changeover switch is in the stop position).
4. Prior to operating the machine, check the safety of the surroundings to avoid accidents.
5. Never move the machine while the preheat flame is on.
6. Take great care of spatters and dross when operating the machine at a high position. They may injure people below.
7. Clutch  
Before running the machine, check to be sure the clutch is in. If the machine runs keeping the clutch by halves, troubles will arise for this reason.
8. When joint the rails, be careful not to catch your hands before the direction after the machine is stopped.
9. When cutting is performed on the rails, be sure to fix the idle wheels.
10. Heat shield should be fixed firmly so that it may not contact the rails.
11. Secure the rack bar with the wing bolt (M6X20) attached to the torch slide liner to prevent the rack bar from dropping.
12. Be sure to hold the handle when carrying the machine.
13. When moving the rails, be sure to take down the machine body off the rails.

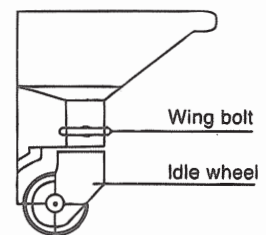

### 1.1.4 Electrical system precautions



1. Be sure to check the input power voltage of the machine before operation. The input power voltage should be in the range of  $\pm 10\%$  of the rated voltage. The machine should not be operated out of this range.
2. The metal plugs are screw-threaded, therefore, fully tighten them so that they will not come loose during operation.
3. Be sure to ground the cable of the machine.
4. Stop operation and turn off the power in the following cases, and ask a qualified electrician to repair the machine.
  - 1) Broken or abraded cables
  - 2) Water leakage from the machine or liquid damage to the machine
  - 3) Abnormal machine operation despite operating the machine according to the instruction manual
  - 4) Machine breakdown
  - 5) Poor machine performance that requires repair
5. Periodically inspect the electrical system.

### 1.1.5 Maintenance and inspection precautions



1. Ask a qualified electrician to perform repair and inspection service.
2. Disconnect the power plug before inspecting and repairing the machine.
3. Maintain the machine periodically.

## 1.2 Gas cutting safety precautions

Strictly observe the safety rules and precautions to ensure the safety of gas cutting operations. Operators and supervisors MUST keep safety in mind.

### 1.2.1 Prevention of explosion



1. Never cut pressurized cylinders or hermetically sealed containers.
2. Ensure sufficient ventilation for gas cutting to prevent the air from becoming stale.

### 1.2.2 Pressure regulator safety precautions



1. Before starting operation, check that all pressure regulators are operating correctly.
2. Ask a skilled repair engineer to perform maintenance and inspection service.
3. Do not use pressure regulators from which gas is leaking, nor malfunctioning pressure regulators.
4. Do not use pressure regulators smeared with oil or grease.

### 1.2.3 High-pressure gas cylinder safety precautions



1. Never use broken cylinders or cylinders from which gas is leaking.
2. Install cylinders upright and take measures to prevent them from falling.
3. Use cylinders only for specified purposes.
4. Do not smear container valves with oil or grease.
5. Install cylinders in a place free from heat, sparks slag, and naked flame.
6. Contact the distributor if the container valves will not open.

Never use a hammer, wrench, or other tools to forcibly open container valves.

### 1.2.4 Safety precautions for hoses



1. Use the oxygen hose for oxygen gas only.
2. Replace cracked hoses or other hoses damaged by sparks, heat, unshielded fire, etc.
3. Install hoses without twisting.
4. To prevent breakage of hoses, take great care during operation and transportation.
5. Do not hold the hoses when moving the machine.
6. Periodically check the hoses for damage, leakage, fatigue, loose joints, etc. to ensure safety.
7. Cut hoses to the minimum possible length. Short hoses reduce hose damage and pressure drop as well as reduce the flow resistance.

### 1.2.4 Safety precautions for fire



Take safety precautions to prevent fire prior to gas cutting. Ignoring hot metal, sparks, and slag could cause a fire.

1. Keep a fire extinguisher, fire extinguishing sand, bucket full of water, etc. ready on the site where gas cutting is performed.
2. Keep flammables away from the cutting area to avoid exposure to sparks.
3. Always cool steel plates that have become hot after cutting, as well as hot cut parts or scrap, before bringing them close to flammables.
4. Never cut containers to which flammable materials are stuck.

## 1.2.6 Safety precautions for skin burns



Observe the safety precautions to prevent skin burns. Ignoring heat, spatter, and sparks during operation could cause a fire or burned skin.

1. Do not perform cutting near flammables. (Move flammables well away from the sparks.)
2. Do not cut containers filled with flammables.
3. Do not keep lighters, matches, and other flammables nearby.
4. Flames from the torch will burn skin. Keep your body away from the torch and tip, and check the safety before operating the switches and valves.
5. Wear the correct protectors to protect your eyes and body.
6. Correctly tighten the tip to prevent backfire.
  - . When fixing a tip to the torch, tighten the nut with the two wrenches attached.
  - . If the tip is tightened excessively, it will be heated during cutting and tightened still more, making it difficult to remove the tip.
  - . Avoid damaging the taper of the tip since this may cause backfire.
7. Check with soapsuds for any leakage of gas from the connection part of the distributor, hose, and torch.

Never use oil or grease on the connection of the oxygen pipe to avoid backfire which may lead to explosion.
8. Be sure to check the following when igniting:
  - . Place the torch on the torch holder before igniting.
  - . Always wear the required protectors (gauntlets, goggles, helmet, etc)
  - . Check for any obstacles, dangerous materials, and flammables near or in the direction of cutting. Determine the gas pressure.
  - . The gas pressure must be within the appropriate range. (For the gas pressure, refer to the Cutting Data.)
9. The torch, tip, and heat shield are heated to a very high temperature. Always wear gauntlets when handling them. Also, the surface after cutting is very hot so do not touch it even while wearing gauntlets.
10. Never move the machine while the preheat flame is on.

## Locations of safety labels

Safety labels and other labels for correct operation are affixed to the machine.

Carefully read the labels and follow the instructions on them when operating the machine.

Never remove the labels. Keep them clean and legible at all times.

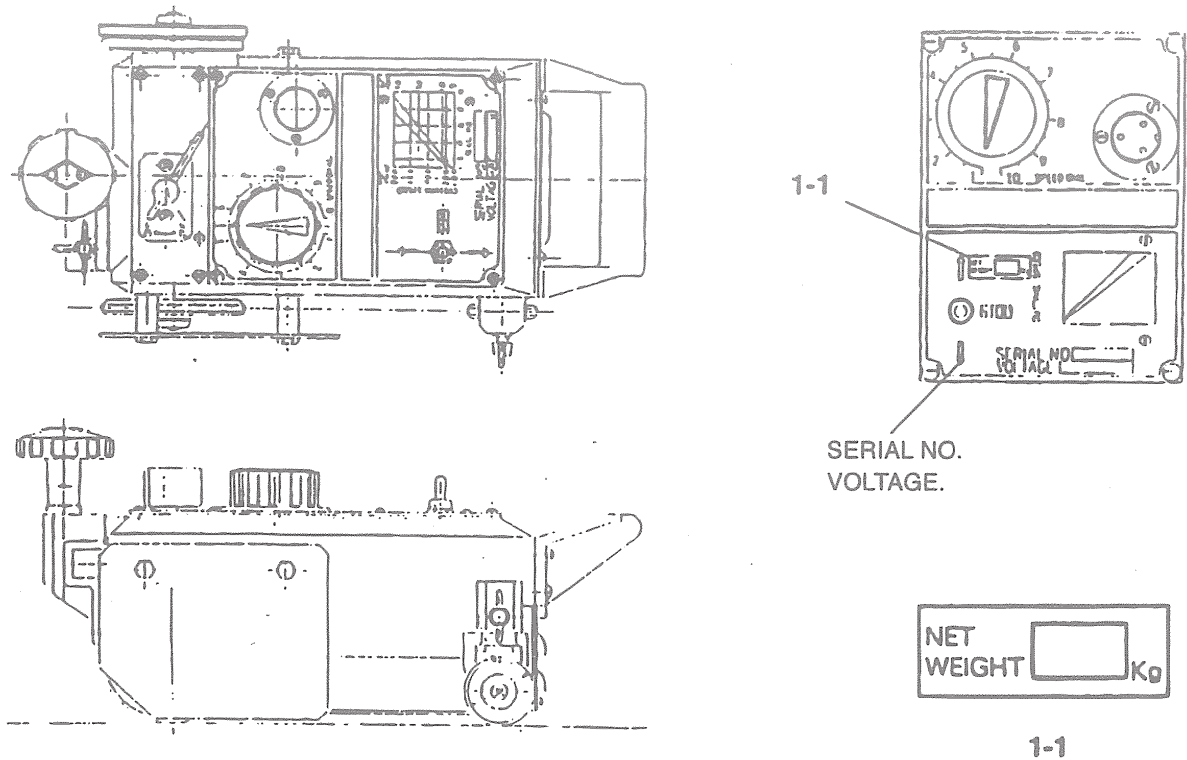

## Outline of machine

### 3.1 Features of machine

This machine is equipped with a single cone speed changer (mechanical non-stage speed changer) to materialize substantial compactness and lightweight based on the double cone speed changer that has been successfully used in UA-12. The improved transportability and operability will surely contribute to rationalization and labor-saving of cutting operation.

### 3.2 Name and function of each section

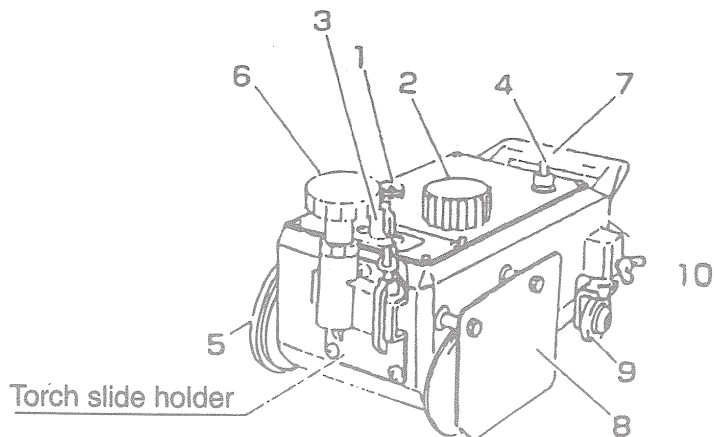

### 1. Metal receptacle

Used for connection of power cable to supply electric power.

### 2. Speed adjuster

Turn the knob clockwise, and the machine will travel faster

### 3. Clutch

The lever operation will stop driving.

### 4. Drive switch

Incline the switch in the direction of the arrow to move the machine in that direction.

### 5. Drive wheel

Engage the clutch (ON) to transmit driving power, and the machine will begin to travel.

### 6. Torch slide handle

This handle adjusts the lateral position of the torch.

### 7. Handle

Hold the handle to carry the machine, as well as for positioning.

### 8. Heat shield

The shield protects the machine from the heating flame.

### 9. Idle wheel

### 10. Case

## 3.3 Specifications

|                       |                                  |
|-----------------------|----------------------------------|
| Weight :              | 7.0 kg                           |
| One torch with Body : | 9.5 kg                           |
| Two torch with Body : | 13 kg                            |
| Machine size :        | 350 x 140 x 175mm                |
| Wheel distance :      | 160mm                            |
| Power source :        | ± 10%                            |
| Reduction gear :      | single cone system               |
| Cutting speed :       | 150-800 mm/mm                    |
| Cutting edge sharp    | 1.V(45°)                         |
| Cutting thickness :   | 5.50mm (by standard accessories) |
| Moter :               | 1500 r.p.m.                      |

## Accessories

|                   |                              |
|-------------------|------------------------------|
| Cabtyre code:     | 1set                         |
| Tip :             | ANM-6L 1/32" , 3/64" , 1/16" |
| Weigh :           | 1 pc (two torch set only)    |
| Weigh supporter : | 1 pc (two torch set only)    |
| Fitting :         | 1 pc (two torch set only).   |

## Option

|                            |                |
|----------------------------|----------------|
| Rail :                     | 1.8m.2.5m.3.0m |
| Circle rail :              |                |
| Circle cutting attachment: |                |

## 4 Preparation for operation

### 4.1 Contents of package

The contents of the standard package are shown below. Check them carefully before assembling the machine.

#### 1. One torch set

|  |       |
|--|-------|
| . Main unit : .....                        | 1 set |
| . Torch holder with rack : .....           | 1 set |
| . Torch : .....                            | 1 pc  |
| . Gas distributor: .....                   | 1 pc  |
| . Hose, 600mm : .....                      | 2 pcs |
| . Cabtyre cord. 5m : .....                 | 1 pc  |
| . Tip ANM-6L 1/32" , 3/64" , 1/16" : ..... | 3 pcs |

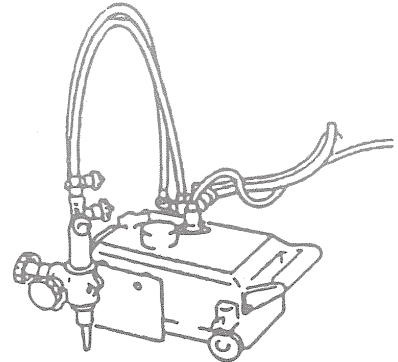

#### 2. Two torch set

|   |       |
|---|-------|
| . Main unit : .....                         | 1 set |
| . Torch holder : .....                      | 2set  |
| . Torch : .....                             | 2pcs  |
| . Gas distributor: .....                    | 1 pc  |
| . Weight : .....                            | 1 pc  |
| . Weight supporter: .....                   | 1 pc  |
| . Fitting : .....                           | 1 pc  |
| . Hose, 600mm (2PCS)and 900mm (2PCS): ..... | 4 pcs |
| . Cabtyre cord. 5m: .....                   | 1 pc  |
| . Tip ANM-6L 1/32" , 3/64" , 1/16" : .....  | 6 pcs |

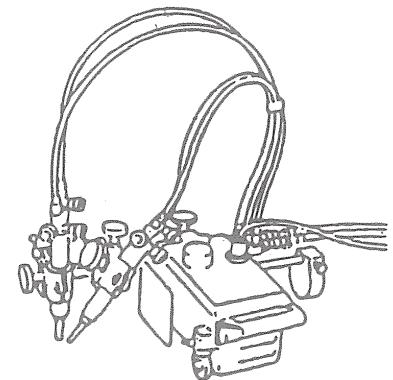

### 4.2 Machine assembly

1. Take out the machine gently from the case and place it on the rail.
2. Assemble the torch set parts in advance in the following order.

#### 4.2.1 One torch set

1. Insert the rack bar into the main unit in the direction of the arrow.

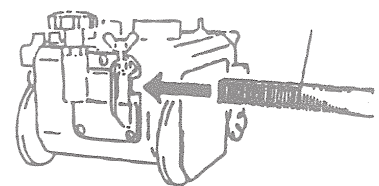

2. Fit the torch holder onto the rack bar.

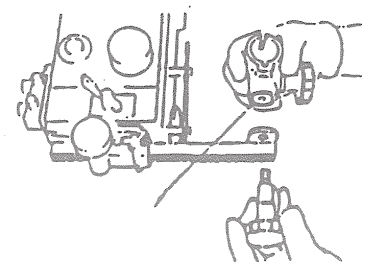

3. Fit the torch into the torch holder and adjust the torch up/down setting.
4. Fit the hoses between the torch and distributor connection. (The blue hose has a right-hand thread, and the red hose a left-hand thread.)

5. When the torch stroke is insufficient to cut the plate beneath the rail when carrying out lower-edgw preparation change the torch holder to the position indicated by the arrow.

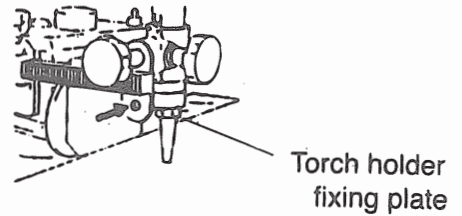

#### 4.2.2 Two torch set

1. Insert the rack bar into the main unit in the direction of the arrow.

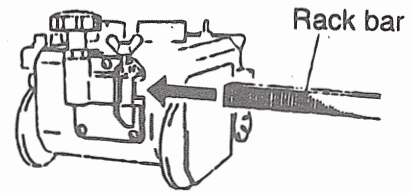

2. Fit the two cross-feed torch holders onto the rack-bar.

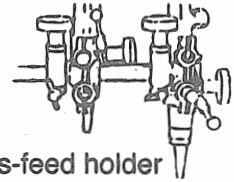

3. Position and fix the torch holders in the cross-feed holders, then fit the torches.

4. Fit the distributor section onto the main unit and connect the 600mm and 900mm hoses from the distributor to the two torches

5. Fix bracket, weight bar and weight, in that order

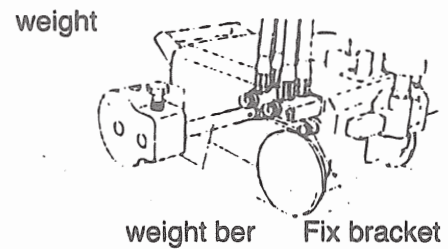

### 4.3 Preparation for operation



#### 4.3.1 Connecting the power cable

1. Connect the power cable to the body.
2. Before plugging the metal plug on the cable side into the socket on the machine side, check there is no dust inside.
3. The metal plugs are screw-threaded. therefore, fully tighten them so that they will not come loose during operation.

#### 4.3.2 Connecting the gas supply hose

1. Connect the respective gas supply hoses to the primary hose.
2. Securely tighten the joints and check there is no gas leak.

#### 4.3.3 Connecting the tip

Select a proper tip according to the thickness of the steel plate and attach it to the torch.  
(To select a tip, refer to the table of cutting data.)

- . When fixing a tip to the torch, tighten the nut with the two wrenches attached.
- . If the tip is tightened excessively, it will be heated during cutting and tightened still more. making it difficult to remove the tip.
- . In addition avoid damaging the taper of the tip since this may cause backfire.

## 5 Cutting operation



### 5.1 Safety measures prior to operation

#### 5.1.1 Grounding the machine



The cable of this machine is equipped with a grounding wire. For safety, be sure to ground the wire as follows, in addition to checking the connection of the power cable.

##### ■ Method to ground the machine

- . The simplest way of grounding the wire is to connect the clip to the steel frame as shown in the diagram.
- . If a grounding wire is already provided at the site, connect the clip to the wire.

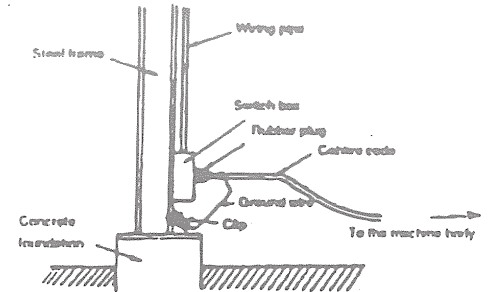

#### 5.1.2 Selection of tip

Referring to the Cutting Data, select the suitable tip according to the plate thickness.

For a heavily rusted plate or for a bevel cutting angle of more than  $20^{\circ}$ , select the tip one grade higher than the one shown in the Cutting Data.

#### 5.1.3 Operation of running direction changeover switch



- . By changing the direction switch, the machine can move forward and backward. The neutral position on the switch is the stop position of the machine.
- . When changing the direction, make sure that the direction switch is in the neutral (stop) position, and operate the direction switch after the machine has stopped.
- . Be sure that the switch is in the neutral position before starting the machine.
- . Make sure that the switch is in the neutral position before turning the power on. If the switch is in the forward or backward position, the machine will start as soon as the power is turned on, which could cause serious accidents.
- . Never put your hands in the space between the guide roller and rail, as well as between the body and the rail, while the machine is running, otherwise, your hands may be caught.

### 5.2 Ignition and flame adjustment

- . Adjust the gas pressure according to the Cutting Data. The data shows the pressure when all the valves are open. Readjust the pressure after ignition. (See page 26.)

##### ■ Flame adjustment method

1. Open the fuel gas valve  $1/4$  to  $1/2$  a turn, and light the torch with an igniter.
2. Then, open the preheating oxygen valve gradually until a white cone of the standard flame has been obtained. (The incandescent area should be uniform and about 5-6 mm (3/16-1/14") in length.)
3. Open the jet oxygen valve fully, Readjust the flame if its condition has changed, A disorderly flow of the jet oxygen will adversely affect the quality of the cutting surface. In such a case, clean the tip with a suitable cleaning needle while the jet oxygen is flowing.
4. A appropriate distance between the tip end and cutting surface:
  - . Acetylene gas .....8-10mm
  - . LPG gas ..... 5-8mm

## 5.3 Cutting and piercing method

1. Cut in from the end of steel plate.
2. Pierce steel plate before cutting.
3. Drill a hole before cutting.

### ■ Piercing method

- 1) Ignite and adjust the flame.
- 2) Thoroughly preheat the cut-in point until it is white hot.
- 3) Open the cutting oxygen valve to pierce the steel plate. The tip should be about 15-20 mm from the plate to prevent slag from splashing onto the tip and adhering there, which will shorten the working life of the tip.

## 5.4 Procedures for starting cutting operation and extinguishing the flame

1. Align the tip with the cutting start point. ignite, and then adjust the flame.
2. Sufficiently preheat the cutting start point.
3. After preheating, supply oxygen and simultaneously turn on the motor switch or the turning direction switch to start cutting.
4. Carefully check the cutting condition and control the cutting speed with the speed adjuster. For the cutting speed, refer to the Cutting Data.
5. Extinguish the flame after cutting as follows:
  - 1) Turn off the motor switch (or turning direction switch).
  - 2) Close the cutting oxygen valve.
  - 3) Close the preheating oxygen valve.
  - 4) Close the fuel gas valve.

## 5.5 Safety measures against backfire and flashback



### 5.5.1 Prevention of backfire



Backfires may cause serious accidents or fires. Be careful to prevent such disaster. When a backfire occurs, find the cause and inspect and maintain the machine correctly before using the machine again.

The following are causes of backfire:

- 1) Improper gas pressure adjustment
- 2) Overheated tip
- 3) Stag clogged in tip
- 4) Damage to the tapered section of the tip or torch will cause backfire.

### 5.5.2 Prevention of flashback



Flashback could cause fire and break the machine. Should there be a hissing sound in the torch, quickly take the following action:

- 1) Close the preheating oxygen valve.
- 2) Close the fuel gas valve.
- 3) Close the cutting oxygen valve.

Should flashback occur, find the cause and take appropriate action before using the machine again.

## 5.6 Cutting operation

1. Attach the rail to the cutting position, and align the tip with the cutting start point.
  2. Bring a flame close to the tip for ignition and ensure sufficient preheating.
  3. Simultaneously with opening the cutting oxygen valve, turn on the switch to start cutting.
  4. While checking the cutting condition, select the optimal cutting speed with the speed adjuster.
  5. After cutting, turn off the switch and close the cutting oxygen valve, fuel gas valve, and preheating oxygen valve in this order.
- \* Thereafter, repeat operations from step 1.

## 5.7 Set up circle cutting attachment

### ■ Option

1. Attach the respective parts, as shown in the figure. for cutting small and large circles.
2. Adjust the height of center by the pivot pin so that the drive wheel of at the center side can be floating by 1mm from the work piece.
3. Align the pivot pin with the center of the circle.
4. Fix the weight as close as possible to the pivot pin.
5. Loosen the butterfly bolt and fix the idle wheel to an angle suitable to the cutting radius.

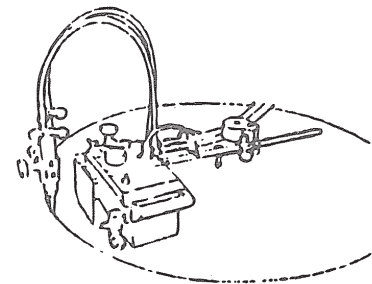
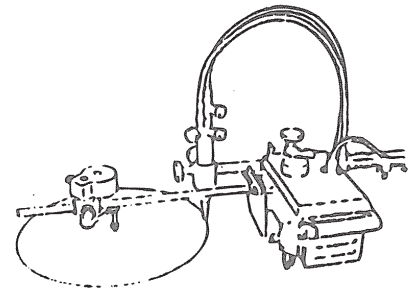

## 5.8 Circle rail

Round rails are available upon request.  
For details, contact the nearest sales office.

## 6. Maintenance and inspection

Refer to the following for inspection and maintenance of the machine to use the machine under the best operating conditions at all times. 6.1 Daily

### 6.1 Daily inspection

1. Wipe the exterior of the machine with a clean cloth.
2. Oil the axles of casters as necessary.
3. Wipe the circumference of the driving wheel with a cloth impregnated with oil.

### 6.2 monthly inspection

1. Oil the torch slide handle shaft and clutch lever shaft.
2. Measure insulation resistance in the following manner; Set the switch in the forward or backward position, and measure the resistance between one end of the power receptacle and the metallic part of the case. If the resistance is 5 k $\Omega$  or more, there is no problem.
3. Disconnect the operation panel, and remove dust from the electric equipment parts.

### 6.3 3-month (2000-hour) inspection

1. Remove the motor and speed change cone, and replace the old grease inside the gear box with new grease. (Grease is available at our sales office.)
2. Replace the internal parts when they are substantially abraded.
3. Completely remove oil, if any, from the motor disc and speed change cone of the speed changer with thinner, etc.

## Troubleshooting

- 1) Carriage does not move. (motor does not run.)

| Possible cause        | Procedure   | Remedy  |
|-----------------------|---|---|
| 1)No electrical power | Check power source and connections  |   |
| 2)Broken power cord   | Use a circuit tester to check the cord. If the tester shows, the power cord is broken.                                    | Repair or replace the broken cord.              |
| 3)Bad plug            | Check wire the soldering.   | Resolving the wire.                             |
| 4)Bad switch          | Remove the mid terminal and test the switch.  | Replace faulty switch. (See the wiring diagram) |
| 5)Bad condenser       | Check the condenser with a tester, if the tester handle slightly vibrates and shows immediately, the condenser is normal. | Replace faulty condenser.                       |
| 6)Bad conduction      | Check soldering.  | Resolving bad connection.                       |
| 7)Damaged lead wire   | Test each lead with a tester.   | Replace faulty lead.                            |
| 8)Bad motor winding's | A faulty motor is indicated if all the above test results are normal.   | Repair or replace the motor.                    |

- 2) Carriage does not move. (motor runs.)

| Possible cause        | Procedure   | Remedy   |
|-----------------------|---|--|
| 1)Faulty clutch       | Remove the clutch and check the inside mechanism. |  |
| 2)Cone friction slips | Check the spring or greasy friction face.         | Replace the spring or clean oily surface with thinner. |

### 3) Abnormal carriage

| Possible cause                | Procedure   | Remedy                             |
|-------------------------------|---|------------------------------------|
| 1) Severe vibration and noise | (1) Foreign matter caught in gear   | Repair or replace.                 |
|                               | (2) Gear worm   | Replace                            |
|                               | (3) Motor faulty  | Repair or replace.                 |
|                               | (4) Cone worm or damaged  | Replace.                           |
| 2) No disengaging             | Snap ring of the clutch pin is off.                                       | Replace.                           |
| 3) Knocks                     | (1) Gear worm   | Replace worm gear.                 |
|                               | (2) Faulty clutch pin   | Replace faulty pin.                |
|                               | (3) Clutch key worm   | Replace worm key.                  |
|                               | (4) Loose shaft or drive wheel  | Repair or replace.                 |
|                               | (5) Worm or damaged cone  | Replace.                           |
|                               | (6) Heat shield touched to the work surface or rail.                      | Exercise caution                   |
|                               | (7) Damaged rail or foreign objects on rail.                              | Repair or clean.                   |
|                               | (8) Hoses or power cord interferes with correaage movement                | Exercise caution during operation. |
|                               | (9) Faulty idle wheel   | Repair or repair.                  |
|                               | (10) Foreign matter is attached to drive wheel, or this wheel is damaged. | Repair or repair.                  |

Note: If the motor does not rotate even after having been repaired, check that wiring is correct.

# Wiring diagram

(100v-120v)

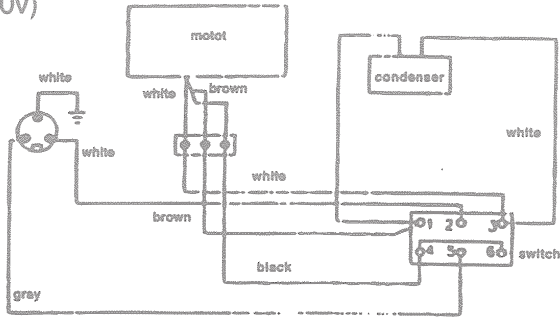

(200v-240v)

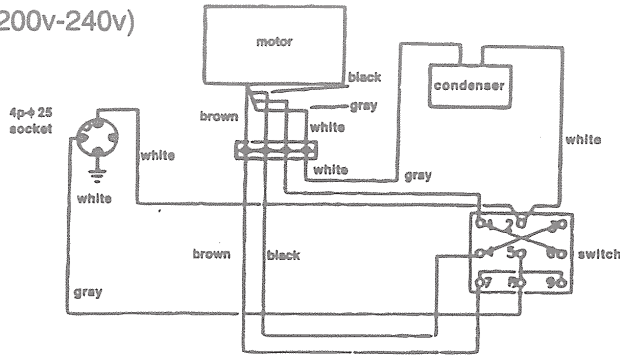

(42v)

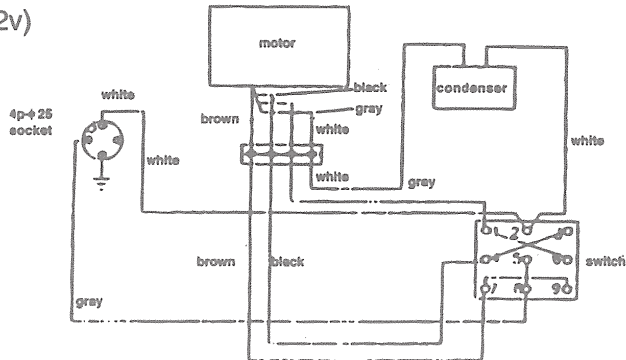

# Assembly drawing

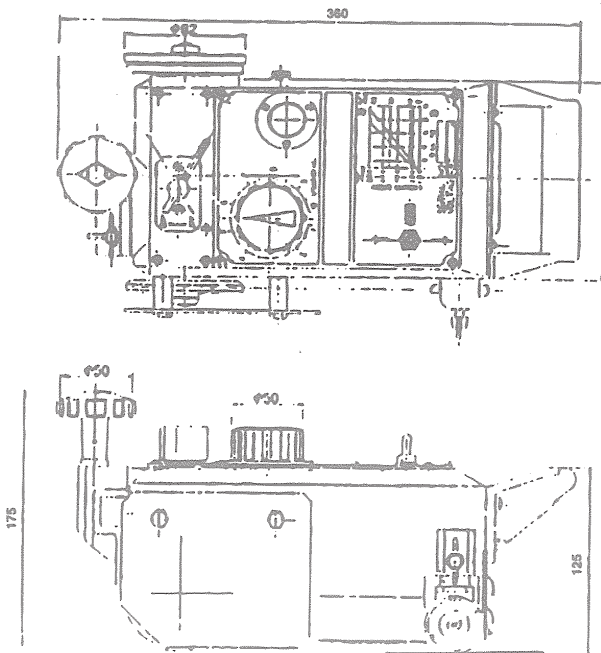

■ **Parts list**  
**10.1 Main units**

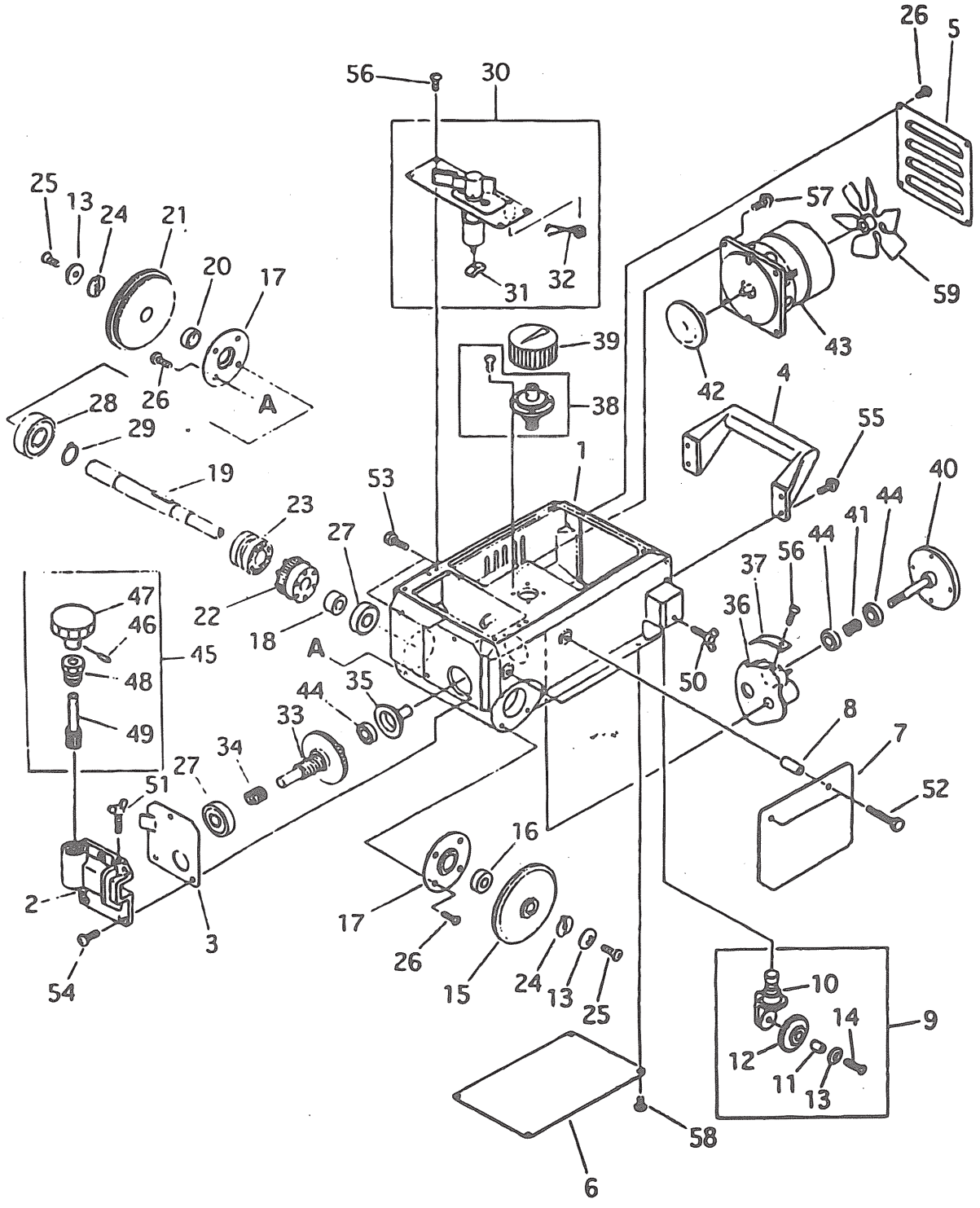

## 10.1 Main units

| ITEM NO. | PART NAME             | QTY | REMARKS  |
|----------|-----------------------|-----|----------|
| 1        | Case                  | 1   |          |
| 2        | Cross feed holder     | 1   |          |
| 3        | Cross feed liner      | 1   |          |
| 4        | Handle                | 1   |          |
| 5        | Fan cover             | 1   |          |
| 6        | Bottom plate          | 1   |          |
| 7        | Heat shield           | 1   |          |
| 8        | Heat shield collar    | 2   |          |
| 9        | Idle wheel unit       | 1   |          |
| 10       | Idle wheel bracker    | 1   |          |
| 11       | Roller shaft          | 1   |          |
| 12       | Roller shaft          | 1   |          |
| 13       | washer                | 1   |          |
| 14       | scren                 | 1   |          |
| 15       | Idle wheel            | 1   |          |
| 16       | collar(A)             | 1   |          |
| 17       | Bearing retainer      | 2   |          |
| 18       | Collar(B)             | 1   |          |
| 19       | Drive wheel shaft     | 1   | with key |
| 20       | Collar(C)             | 1   |          |
| 21       | Drive wheel           | 1   |          |
| 22       | Worm wheel            | 1   |          |
| 23       | Clutch                | 1   |          |
| 24       | Washer                | 2   |          |
| 25       | Screw                 | 2   |          |
| 26       | Screw                 | 2   |          |
| 27       | Bearing               | 2   | 6300ZZ   |
| 28       | Bearing               | 1   | 6302ZZ   |
| 29       | Stop ring             | 1   |          |
| 30       | clutch lever assembly | 1   |          |
| 31       | Slider                | 1   |          |
| 32       | Clutch spring         | 1   |          |
| 33       | Worm shaft assembly   | 1   |          |
| 34       | Worm spring           |     |          |

| ITEM NO. | PART NAME                 | QTY | REMARKS            |
|----------|---------------------------|-----|--------------------|
| 35       | Speed adjusting shaft     | 1   |                    |
| 36       | Speed adjusting bracket   | 1   |                    |
| 37       | Rack                      | 1   |                    |
| 38       | Speed adjusting handle    | 1   |                    |
| 39       | Speed adjusting knob      | 1   |                    |
| 40       | Speed adjusting cone assy | 1   |                    |
| 41       | Cone spring               | 1   |                    |
| 42       | Motor disk                | 1   |                    |
| 43       | Motor                     | 1   | 100V-120           |
|          | Motor                     | 1   | 200V-220           |
|          | Motor                     | 1   | 230V-240           |
|          | Motor                     | 1   | 42V                |
| 44       | Bearing                   | 1   | 608ZZ              |
| 45       | Cross feed pinion unit    | 1   |                    |
| 46       | Spring pin                | 1   |                    |
| 47       | handle(Ø 40)              | 1   |                    |
| 48       | Pinion meral              | 1   |                    |
| 49       | Pinion                    | 1   |                    |
| 50       | Wing bolt                 | 1   |                    |
| 51       | Wing bolt                 | 1   |                    |
| 52       | Hexagon bolt              | 2   |                    |
| 53       | Hexagon bolt              | 2   |                    |
| 54       | Screw                     | 3   |                    |
| 55       | Screw                     | 4   | with spring washer |
| 56       | Screw                     | 10  |                    |
| 57       | Screw                     | 4   |                    |
| 58       | Screw                     | 8   |                    |
| 59       | Motor Fan                 | 1   | with screw         |

## 10.2 Electrical, gas and torch slide holder units

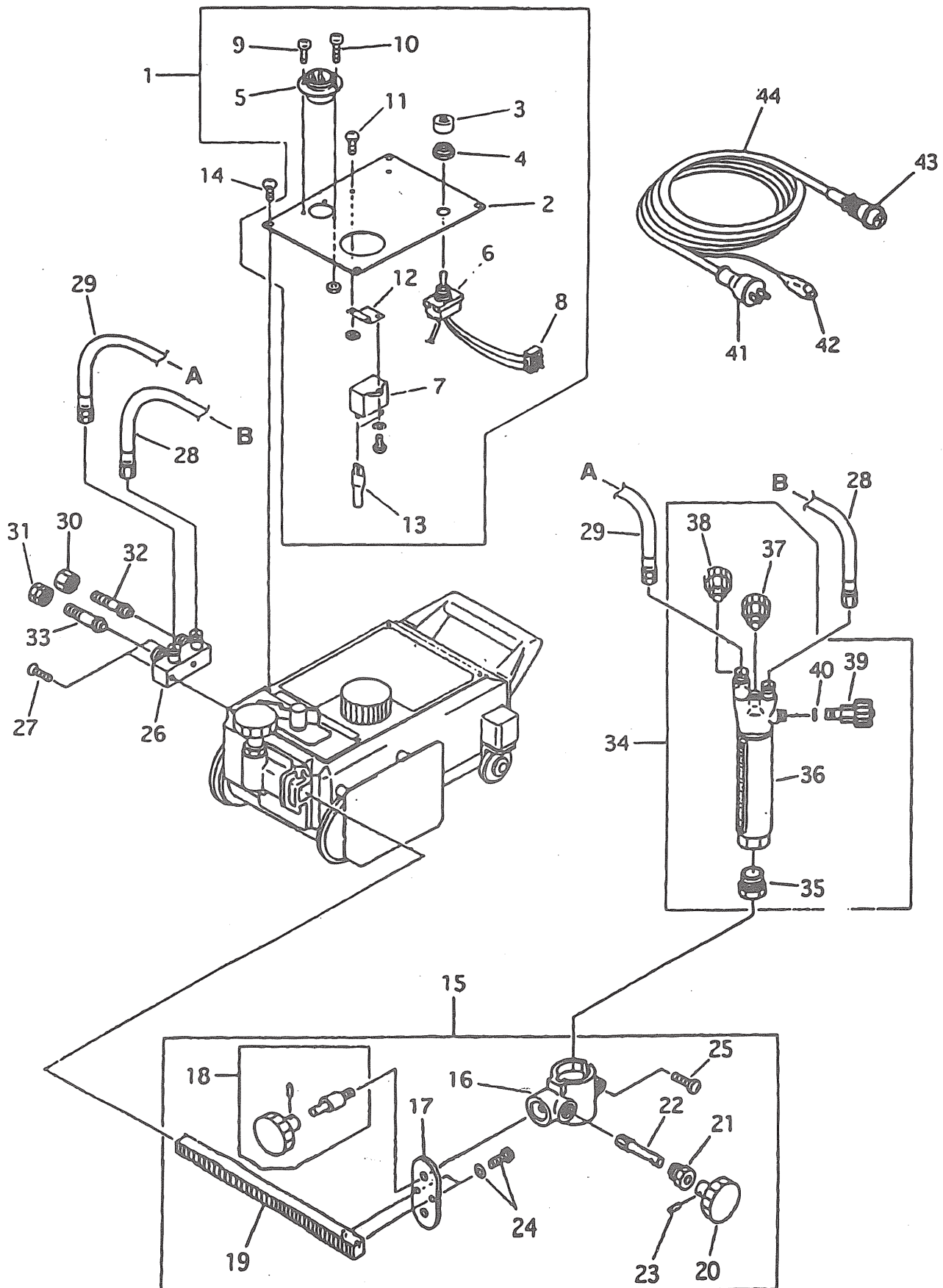

## 10.2 Electrical, gas and torch slide holder units

| ITEM NO. | PART NAME                 | QTY | REMARKS          |
|----------|---------------------------|-----|------------------|
| 1        | Panel assembly            | 1   | 100V-240V        |
|          | Panel assembly            | 1   | 200V-240V        |
|          | Panel assembly            | 1   | 42V              |
| 2        | Panel                     | 1   |                  |
| 3        | Cap for dust protector    | 1   |                  |
| 4        | Nut for dust protector    | 1   |                  |
| 5        | Metal socket              | 1   | 3P               |
|          | Metal socket              | 1   | 4P               |
| 6        | Switch                    | 1   | 100V-120V        |
|          | Switch                    | 1   | 200V-240V<br>42V |
| 7        | Condenser                 | 1   | 100V             |
|          | Condenser                 | 1   | 120V             |
|          | Condenser                 | 1   | 200V-220V        |
|          | Condenser                 | 1   | 230V-240V        |
|          | Condenser                 | 1   | 42V              |
| 8        | Terminal                  | 1   | 100V-120V 3P     |
|          | Terminal                  | 1   | 200V-240V 4P     |
| 9        | Screw                     | 2   | With nut         |
| 10       | Screw                     | 1   | with nu          |
| 11       | Screw                     | 2   |                  |
| 12       | Condenser fixing plate    | 1   |                  |
| 13       | Fston terminal            | 2   |                  |
| 14       | Screw                     | 4   |                  |
| 15       | Torch holder assembly     | 1   |                  |
| 16       | Torch holder              | 1   |                  |
| 17       | Torch holder fixing plate | 1   |                  |
| 18       | Holder fixing handle      | 1   |                  |
| 19       | Rack bar                  | 1   |                  |
| 20       | Handle(Ø 40)              | 1   |                  |
| 21       | Pinion metal              | 1   |                  |
| 22       | Pinion                    | 1   |                  |
| 23       | Spring Pin                | 1   |                  |
| 24       | Hexagon bolt              | 2   | with WS          |
| 25       | Screw                     | 1   |                  |

| ITEM NO. | PART NAME                | QTY | REMARKS                  |
|----------|--------------------------|-----|--------------------------|
| 26       | Distributor              | 1   | Expxct USAKE             |
|          | Distributor              | 1   | USA only                 |
|          | Distributor              | 1   | KE only                  |
| 27       | Screw                    | 2   |                          |
| 28       | Hose for oxygen          | 1   | M12X600<br>Except USA KE |
|          | Hoes for oxygen          | 1   | USA only                 |
|          | Hose for oxygen          | 1   | Except USA               |
| 29       | Hose for gas             | 1   | KE only<br>Except USA    |
|          | Hose for gas             | 1   | USA only                 |
| 30       | Nut for oxygen           | 1   | Except USA               |
|          | Nut for oxygen           | 1   | KE only                  |
| 31       | Nut for gas              | 1   | Except USA               |
|          | Nut for gas              | 1   | KE only                  |
| 32       | Hese connector(ox)       | 1   | Except USA               |
|          | Hose connector(ox)       | 1   | KE only                  |
| 33       | Hose connector(gas)      | 1   | Except USA               |
|          | Hose connector(gas)      | 1   | KE only                  |
| 34       | Torch                    | 1   | Facer<br>USAKE           |
|          | Torch                    | 1   | Except USA               |
| 35       | Torch                    | 1   | KE only                  |
| 36       | Tip fixing nut           | 1   |                          |
| 37       | Rack for Beetle          | 1   | with screw               |
|          | Valve for preheat oxygen | 1   | Except KE                |
| 38       | Valve for preheat oxygen | 1   | KE only                  |
| 39       | Valve for gas            | 1   |                          |
|          | Valve for jet for oxygen | 1   | Except KE                |
| 40       | Valve for jet for oxygen | 1   | KE only                  |
| 41       | O-ring                   | 1   |                          |
| 42       | Rubber plug              | 1   |                          |
| 43       | Earth clip               | 1   |                          |
|          | Metal plug               | 1   | 4P                       |
|          | Metal Pluy               | 1   | 4P                       |
| 44       | Cabtyre cord assembly    | 1   | 4P                       |
|          | Cabtyre cord assembly    | 1   | 4P                       |

## 10.3 Two torch unit

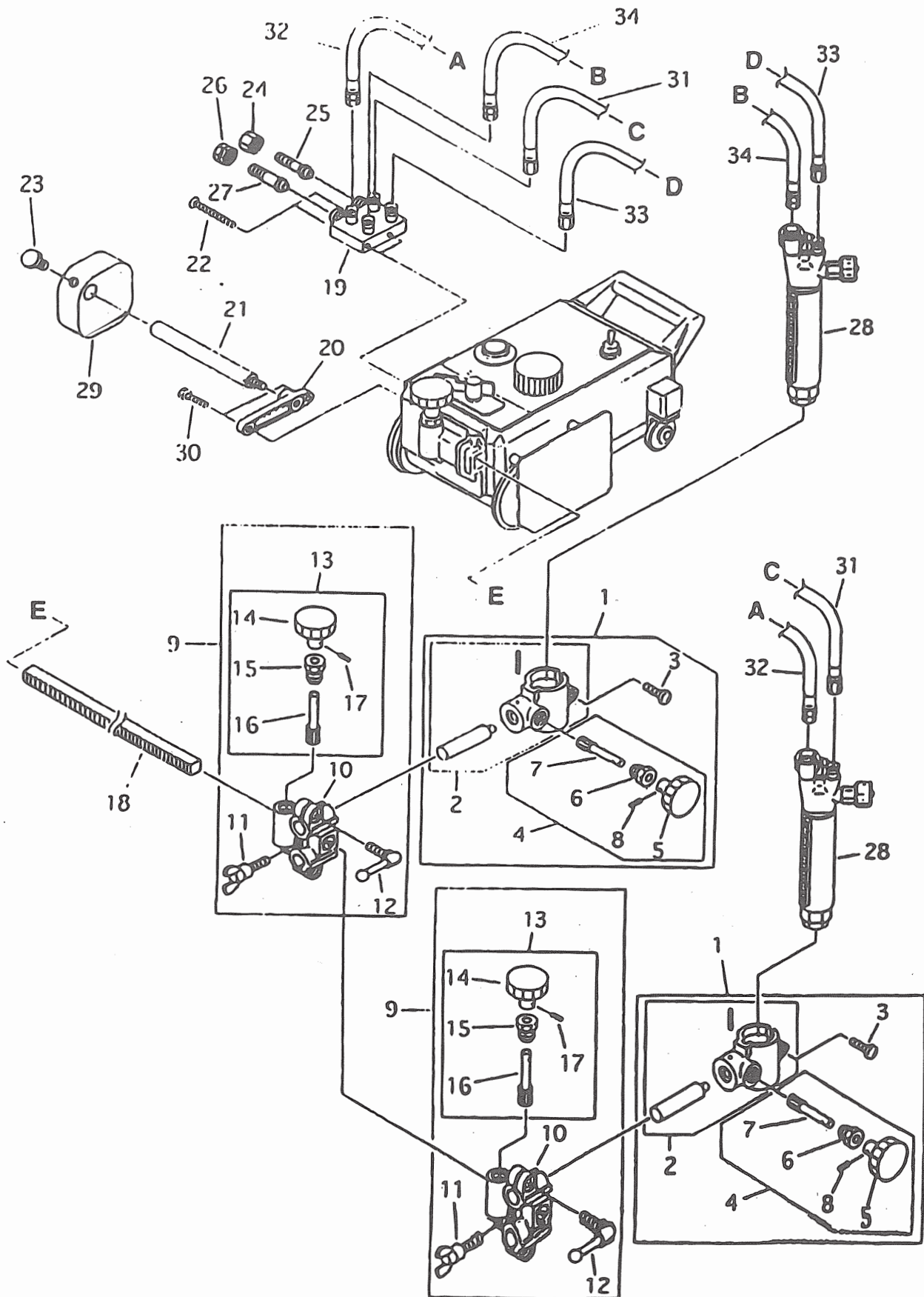

### 10.3 Tow torch unit

| ITEM NO. | PART NAME               | QTY | REMARKS       |
|----------|-------------------------|-----|---------------|
| 1        | Torch holder assembly   | 2   |               |
| 2        | Torch holder            | 2   |               |
| 3        | Screw                   | 2   |               |
| 4        | Torch up/down handle    | 2   |               |
| 5        | Handle(φ40)             | 2   |               |
| 6        | Pinion metal            | 2   |               |
| 7        | Pinion                  | 2   |               |
| 8        | Spring pin              | 2   |               |
| 9        | Torch cross feed holder | 2   |               |
| 10       | Cross feed holder       | 2   |               |
| 11       | Wing bolt               | 2   |               |
| 12       | Crank handle            | 2   |               |
| 13       | Cross feed pinion unit  | 2   |               |
| 14       | Handle (φ40)            | 2   |               |
| 15       | Pinion metal            | 2   |               |
| 16       | Pinion                  | 2   |               |
| 17       | Spring pin              | 2   |               |
| 18       | Rack bar                | 1   |               |
| 19       | Distributor             | 1   | Except USA,KE |
|          | Distributor             | 1   | KE only       |
|          | Distributor             | 1   | USA only      |
| 20       | Fitting                 | 1   |               |
| 21       | Weight supporter        | 1   |               |
| 22       | Screw                   | 2   |               |
| 23       | Hexagen bolt            | 1   |               |
| 24       | Nut for oxygen          | 1   | Except USA    |
|          | Nut for oxygen          | 1   | KE only       |
| 25       | Hose connector(ox)      | 1   | Except USA    |
|          | Hose connector(ox)      | 1   | KE only       |
| 26       | Nut for gas             | 1   | Except USA    |
|          | Nut for gas             | 1   | KE only       |
| 27       | Hose connector(gas)     | 1   | Except USA    |
|          | Hose connector(gas)     | 1   | KE only       |

| ITEM NO. | PART NAME       | QTY | REMARKS                      |
|----------|-----------------|-----|------------------------------|
| 28       | Torch           | 2   | Except USA, KE               |
|          | Torch           | 2   | USA only                     |
|          | Torch           | 2   | KE only                      |
| 29       | Weight          | 1   |                              |
| 30       | Hexagon bolt    | 2   |                              |
| 31       | Hose for oxygen | 1   | M12X900<br>Except USA,KE     |
|          | Hose for oxygen | 1   | USA only                     |
|          | Hose for oxygen | 1   | KE only                      |
| 32       | Hose for gas    | 1   | M12X900 lnh<br>Except USA,KE |
|          | Hose for gas    | 1   | USA only                     |
| 33       | Hose for oxygen | 1   | M12X600                      |
|          | Hose for oxygen | 1   | USA only                     |
|          | Hose for oxygen | 1   | KE only                      |
| 34       | Hose for gas    | 1   | M12X600lnh                   |
|          | Hose for gas    | 1   | USA only                     |

## 1 1 Cutting data

106 (STANDARD SPEED) For Propane  
Metric System

| PLATE THICKNESS (mm) | TIP SIZE | CUTTING SPEED (mm/min) | OXYGEN PRESSURE (kg/cm <sup>2</sup> ) |         | FUEL GAS PRESSURE (kg/cm <sup>2</sup> ) | KERF WIDTH (mm) |
|----------------------|----------|------------------------|---------------------------------------|---------|---|-----------------|
|                      |          |                        | CUTTING                               | PR-HEAT |   |                 |
| 3                    | 1/32     | 680                    | 1.5                                   | 1.5     | 0.2                                     | 1.0             |
| 6                    | 1/32     | 610                    | 2.0                                   | 2.0     | 0.2                                     | 1.3             |
| 10                   | 3/64     | 560                    | 2.0                                   | 2.0     | 0.2                                     | 1.5             |
| 12.5                 | 3/64     | 530                    | 2.5                                   | 2.5     | 0.2                                     | 1.8             |
| 19                   | 3/64     | 460                    | 3.0                                   | 3.0     | 0.25                                    | 2.0             |
| 25                   | 1/16     | 430                    | 3.0                                   | 3.0     | 0.25                                    | 2.0             |
| 38                   | 1/16     | 355                    | 3.0                                   | 3.0     | 0.25                                    | 2.3             |
| 50                   | 1/16     | 320                    | 3.0                                   | 3.0     | 0.25                                    | 2.8             |
| 60                   | 1/16     | 280                    | 4.0                                   | 4.0     | 0.3                                     | 3.0             |
| 75                   | 1/16     | 250                    | 4.0                                   | 4.0     | 0.3                                     | 3.0             |
| 100                  | 5/64     | 200                    | 4.0                                   | 4.0     | 0.3                                     | 3.6             |
| 125                  | 5/64     | 180                    | 4.0                                   | 4.0     | 0.4                                     | 3.6             |
| 150                  | 3/32     | 150                    | 4.5                                   | 4.5     | 0.4                                     | 4.1             |
| 200                  | 1/8      | 130                    | 4.5                                   | 4.5     | 0.4                                     | 4.3             |
| 250                  | 1/8      | 80                     | 4.5                                   | 4.5     | 0.4                                     | 5.6             |
| 300                  | 1/8      | 50                     | 4.5                                   | 4.5     | 0.4                                     | 6.6             |

Inch System

| PLATE THICKNESS (inches) | TIP SIZE | CUTTING SPEED (in.min) | OXYGEN P.S.I.G |         | FUEL GAS P.S.I.G | KERF WIDTH (inches) |
|--------------------------|----------|------------------------|----------------|---------|------------------|---------------------|
|                          |          |                        | CUTTING        | PR-HEAT |                  |                     |
| 1/8                      | 1/32"    | 27                     | 20             | 20      | 2.8              | 0.04                |
| 1/4                      | 1/32"    | 24                     | 30             | 30      | 2.8              | 0.05                |
| 3/8                      | 3/64"    | 22                     | 30             | 30      | 2.8              | 0.06                |
| 1/2                      | 3/64"    | 21                     | 40             | 40      | 2.8              | 0.07                |
| 3/4                      | 3/64"    | 18                     | 45             | 45      | 3.6              | 0.08                |
| 1                        | 1/16"    | 17                     | 45             | 45      | 3.6              | 0.08                |
| 1-1/2                    | 1/16"    | 14                     | 45             | 45      | 3.6              | 0.09                |
| 2                        | 1/16"    | 12.5                   | 45             | 45      | 4.3              | 0.11                |
| 2-1/2                    | 1/16"    | 11                     | 55             | 55      | 4.3              | 0.12                |
| 3                        | 1/16"    | 10                     | 55             | 55      | 4.3              | 0.12                |
| 4                        | 5/64"    | 8                      | 55             | 55      | 5.7              | 0.14                |
| 5                        | 5/64"    | 7                      | 55             | 55      | 5.7              | 0.14                |
| 6                        | 3/32"    | 6                      | 65             | 65      | 5.7              | 0.16                |
| 8                        | 1/8"     | 5                      | 65             | 65      | 5.7              | 0.17                |
| 10                       | 1/8"     | 3                      | 65             | 65      | 5.7              | 0.23                |
| 12                       | 1/8"     | 2                      | 65             | 65      | 5.7              | 0.27                |

- Note:
- 1) All pressures are torch inlet pressures.
  - 2) Oxygen purity is minimum of 99.7% ; propane is minimum of JIS Grade 3.
  - 3) Depending on the surface condition of the steel plate (scale, paint), either increase the fuel gas pressure decrease cutting speed. Also, when precision cutting is required, adjust all data.

102 (STANDARD SPEED) For Acetylene

| PLATE THICKNESS (mm) | TIP SIZE | CUTTING SPEED (mm/min) | OXYGEN PRESSURE (kg/cm <sup>2</sup> ) |         | FUEL GAS PRESSURE (kg/cm <sup>2</sup> ) | KERF WIDTH (mm) |
|----------------------|----------|------------------------|---------------------------------------|---------|---|-----------------|
|                      |          |                        | CUTTING                               | PR-HEAT |   |                 |
| 3                    | 1/32     | 680                    | 1.5                                   | 1.5     | 0.2                                     | 1.0             |
| 6                    | 1/32     | 610                    | 2.0                                   | 2.0     | 0.2                                     | 1.3             |
| 10                   | 3/64     | 560                    | 2.0                                   | 2.0     | 0.2                                     | 1.5             |
| 12.5                 | 3/64     | 530                    | 2.5                                   | 2.5     | 0.2                                     | 1.8             |
| 19                   | 3/64     | 460                    | 3.0                                   | 3.0     | 0.2                                     | 2.0             |
| 25                   | 1/16     | 430                    | 3.0                                   | 3.0     | 0.2                                     | 2.0             |
| 38                   | 1/16     | 355                    | 3.0                                   | 3.0     | 0.2                                     | 2.3             |
| 50                   | 1/16     | 320                    | 3.0                                   | 3.0     | 0.25                                    | 2.8             |
| 60                   | 1/16     | 280                    | 4.0                                   | 4.0     | 0.3                                     | 3.0             |
| 75                   | 1/16     | 250                    | 4.0                                   | 4.0     | 0.3                                     | 3.0             |
| 100                  | 5/64     | 200                    | 4.0                                   | 4.0     | 0.35                                    | 3.6             |
| 125                  | 5/64     | 180                    | 4.0                                   | 4.0     | 0.35                                    | 3.6             |
| 150                  | 3/32     | 150                    | 4.5                                   | 4.5     | 0.4                                     | 4.1             |
| 200                  | 1/8      | 130                    | 4.5                                   | 4.5     | 0.4                                     | 4.3             |
| 250                  | 1/8      | 80                     | 4.5                                   | 4.5     | 0.4                                     | 5.6             |
| 300                  | 1/8      | 50                     | 4.5                                   | 4.5     | 0.4                                     | 6.6             |

Inch System

| PLATE THICKNESS (inches) | TIP SIZE | CUTTING SPEED (in.min) | OXYGEN P.S.I.G |         | FUEL GAS P.S.I.G | KERF WIDTH (inches) |
|--------------------------|----------|------------------------|----------------|---------|------------------|---------------------|
|                          |          |                        | CUTTING        | PR-HEAT |                  |                     |
| 1/8                      | 1/32"    | 27                     | 20             | 20      | 2.8              | 0.04                |
| 1/4                      | 1/32"    | 24                     | 30             | 30      | 2.8              | 0.05                |
| 3/8                      | 3/64"    | 22                     | 30             | 30      | 2.8              | 0.06                |
| 1/2                      | 3/64"    | 21                     | 40             | 40      | 2.8              | 0.07                |
| 3/4                      | 3/64"    | 18                     | 45             | 45      | 2.8              | 0.08                |
| 1                        | 1/16"    | 17                     | 45             | 45      | 2.8              | 0.08                |
| 1-1/2                    | 1/16"    | 14                     | 45             | 45      | 2.8              | 0.09                |
| 2                        | 1/16"    | 12.5                   | 45             | 45      | 3.6              | 0.11                |
| 2-1/2                    | 1/16"    | 11                     | 55             | 55      | 4.3              | 0.12                |
| 3                        | 1/16"    | 10                     | 55             | 55      | 4.3              | 0.12                |
| 4                        | 5/64"    | 8                      | 55             | 55      | 5.0              | 0.14                |
| 5                        | 5/64"    | 7                      | 55             | 55      | 5.0              | 0.14                |
| 6                        | 3/32"    | 6                      | 65             | 65      | 5.7              | 0.16                |
| 8                        | 1/8"     | 5                      | 65             | 65      | 5.7              | 0.17                |
| 10                       | 1/8"     | 3                      | 65             | 65      | 5.7              | 0.23                |
| 12                       | 1/8"     | 2                      | 65             | 65      | 5.7              | 0.27                |

- Note: 1) All pressures are torch inlet pressures.  
 2) Oxygen purity is minimum of 99.7%  
 3) Depending on the surface condition of the steel plate (scale, paint), either increase the fuel gas pressure or decrease cutting speed. Also, when precision cutting is required, adjust all data.



